

Low-Noise, Phase-Locked Loop Clock Driver with 10 Clock Outputs

Features

- Operating Frequency up to 150 MHz
- Low-Noise Phase-Locked Loop Clock Distribution that meets 133 MHz Registered DIMM Synchronous DRAM modules for server/workstation/PC applications
- Allows Clock Input to have Spread Spectrum modulation for EMI reduction
- Low jitter: Cycle-to-Cycle jitter ± 75 ps max.
- On-chip series damping resistor at clock output drivers for low noise and EMI reduction
- Operates at 3.3V VCC, 0–85°C
- Packages (Pb-free & Green available):
 - Plastic 24-pin TSSOP (L)

Description

The PI6C2510-133E is a “enhanced,” low-skew, low-jitter, phase-locked loop (PLL) clock driver, distributing high-frequency clock signals for SDRAM and server applications. By connecting the feedback FB_OUT output to the feedback FB_IN input, the propagation delay from the CLK_IN input to any clock output will be nearly zero. This zero-delay feature allows the CLK_IN input clock to be distributed, providing one clock input to one bank of ten outputs, with an output enable.

This clock driver is designed to meet the PC133 SDRAM Registered DIMM specification. For test purposes, the PLL can be bypassed by strapping AVCC to ground.

Block Diagram

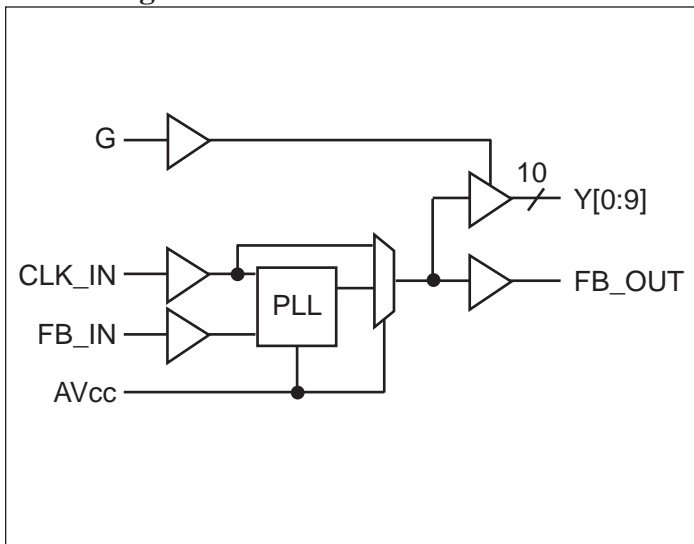

Pin Configuration

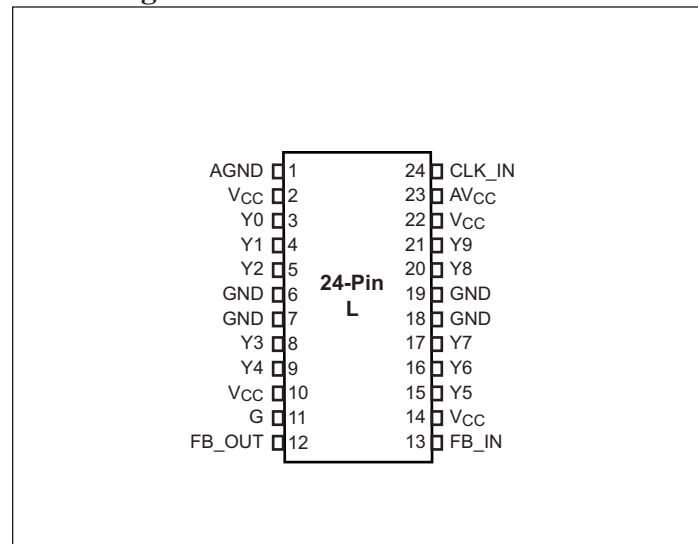

Functional Table

Inputs	Outputs	
G	Y[0:9]	FB_OUT
L	L	CLK_IN
H	CLK_IN	CLK_IN

Pin Functions

Pin Name	Pin Number	Type	Description
CLK_IN	24	I	Reference Clock input. CLK_IN allows spread spectrum.
FB_IN	13	I	Feedback input. FB_IN provides the feedback signal to the internal PLL.
G	11	I	Output bank enable. When G is LOW, outputs Y[0:9] are disabled to a logic low state. When G is HIGH, all outputs Y[0:9] are enabled.
FB_OUT	12	O	Feedback output. FB_OUT is dedicated for external feedback. FB_OUT has an embedded series-damping resistor of same value as clock outputs Y[0:9].
Y[0:9]	3, 4, 5, 8, 9, 15, 16, 17, 20, 21	O	Clock outputs. These outputs provide low-skew copies of CLK_IN. Each output has an embedded series-damping resistor.
AV _{CC}	23	Power	Analog power supply. AV _{CC} can be also used to bypass the PLL for test purposes. When AV _{CC} is strapped to ground, PLL is bypassed and CLK_IN buffered directly to the device outputs.
AGND	1	Ground	Analog ground. AGND provides the ground reference for the analog circuitry/
V _{CC}	2, 10, 14, 22	Power	Power Supply
GND	6, 7, 18, 19	Ground	Ground

DC Specifications - Absolute maximum ratings over operating free-air temperature range.

Symbol	Parameter	Min.	Max.	Units
V _I	Input voltage range	-0.5	V _{CC} + 0.5	V
V _O	Output voltage range			
V _{I_DC}	DC input voltage		+5.0	
I _{O_DC}	DC output current		100	mA
Power	Maximum power dissipation at TA = 59°C in still air		1.0	W
T _{STG}	Storage temperature	-65	160	°C

Note: Stress beyond those listed under “absolute maximum ratings” may cause permanent damage to the device.

Parameter	Test Conditions	V _{CC}	Min	Typ	Max	Units
I _{CC}	V _I = V _{CC} or GND; I _O = 0	3.6V			10	uA
C _I	V _I = V _{CC} or GND	3.3V		4		pF
C _O	V _O = V _{CC} or GND			6		

Recommended Operating Conditions

Symbol	Parameter	Min.	Max.	Units
V _{CC}	Supply voltage	3.0	3.6	V
V _{IH}	High level input voltage	2.0		
V _{IL}	Low level input voltage		0.8	
V _I	Input Voltage	0.0	V _{CC}	
T _A	Operating free-air temperature	0	85	°C

Electrical Characteristics (Over recommended operating free-air temperature range.)

Pull Up/Down Currents of PI6C2510-133E, V_{CC} = 3.0V

Symbol	Parameter	Condition	Min	Max	Units
I _{CH}	Pull-up current	V _{OUT} = 2.4V		-13.6	mA
	Pull-up current	V _{OUT} = 2.0V		-22	
I _{CIL}	Pull-down current	V _{OUT} = 0.8V	19		
	Pull-down current	V _{OUT} = 0.55V	13		

AC Specifications - Timing requirements over recommended ranges of supply voltage and operating free-air temperature.

Symbol	Parameter	Min	Max	Units
F _{CLK}	Input Clock Frequency	25	150	MHz
	Input Clock Duty Cycle	40	60	%
	Stabilization Time after power up		1	ms

Switching Characteristics (Over recommended ranges of supply voltage and operating free-air temperature, CL=30pF.)

Parameter	From	To	V _{CC} = 3.3V ± 0.3V, 0-85°C			Units
			Min.	Typ.	Max.	
t _{phase error} , with and without spread spectrum	CLK_IN↑ at 133MHz	FB_IN↑	-150		+150	ps
Jitter, cycle-to-cycle, with and without spread spectrum	Any Output or FB_OUT in CLK _n at 133 MHz	Output or FB_OUT in CLK _{n+1}	-75		+75	
Skew, at 133 MHz	Any Y or FB_OUT	Any Y or FB_OUT			150	
Duty Cycle			45	50	55	%
t _r , rise-time, 0.4V to 2.0V				1.0		ns
t _f , fall-time, 2.0V to 0.4V				1.1		

Note: These switching parameters are guaranteed, but not production tested.

Packaging Mechanical: Plastic 24-pin Thin Shrink Small-Outline Package (L)

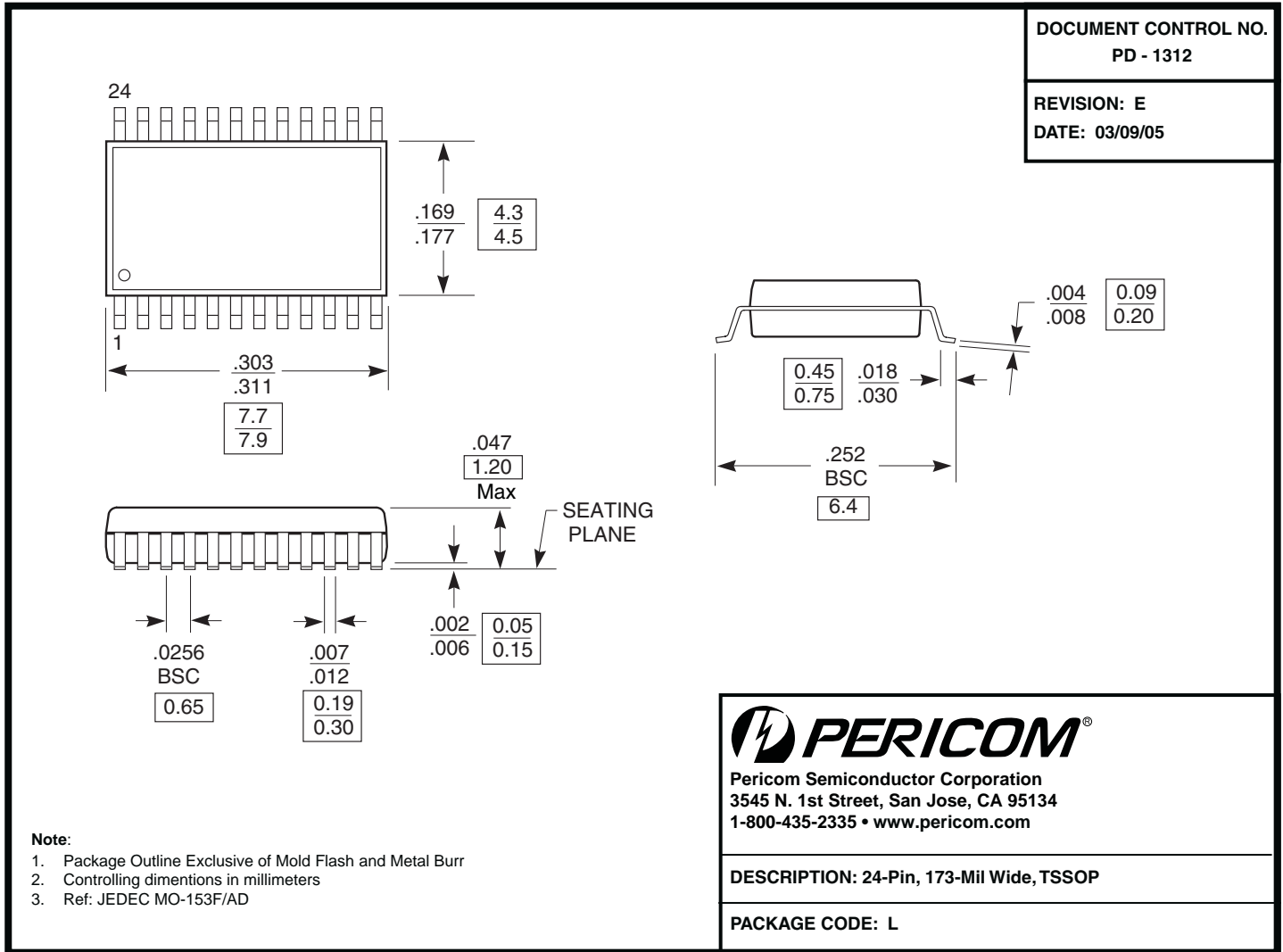

Order Information

Ordering Code	Packaging Code	Packaging Description	Frequency Range
PI6C2510-133EL	L	24-pin plastic TSSOP	25MHz - 150MHz
PI6C2510-133ELE	L	Pb-Free & Green 24-pin plastic TSSOP	25MHz - 150MHz